

**Models Covered**

253-TCA            25D-ODA            9D-ODA

**Installation**

The 253-TCA should be installed in a dry position, not in direct sunlight and where the ambient temperature is reasonably stable and will not be outside the range 0 to 60° C during operation. Mounting will normally be on a vertical surface but other positions will not affect operation. Vibration should be kept to a minimum.

To mount the unit on a DIN rail, the top edge of the cut-out on the back is hooked over one edge of the rail and the bottom edge carrying the release clip clicked in place. Check that the unit is firmly fixed. Removal or repositioning may be achieved by levering down the release clip and lifting the unit up and off the rail.

Connection wires should be sized to comply with applicable regulations or code of practice.

The 253-TCA adaptor is available with an RS232 output via twisted pair or optical cable. Where optical cable is used, the start of the cable is simply pushed into the socket and the nut turned to form a secure fixing. The remote end of the cable can similarly be accommodated on the Crompton 25D-ODA or 9D-ODA optical-to-digital adaptor which converts the optical pulsed signal into electrical signals on a standard 25 or 9 pin D plug. This adaptor does not require an auxiliary power source as it derives power from handshake signals, and is wired DCE.

The simple *cut-and-finger* nut cable termination method requires less skill than the soldering of a D socket. The cut cable ends need not be polished.

We also offer a demonstration disc, comprehensive data and the full Crompton service and technical support. Application advice is available to help you design this product into your system. See page 2 for details of our Sales Offices.

**Electromagnetic Compatibility**

This unit has been designed to provide protection against EM (electro-magnetic) interference in line with requirements of EU and other regulations. Precautions necessary to provide proper operation of this and adjacent equipment will be installation dependent and so the following can only be general guidance:-

- Avoid routing wiring to this unit alongside cables and products that are, or could be, a source of interference.
- The auxiliary supply to the unit should not be subject to excessive interference. In some cases, a supply line filter may be required.
- To protect the product against incorrect operation or permanent damage, surge transients must be controlled. It is good EMC practice to suppress differential surges to 2kV or less at the source. The unit has been designed to automatically recover from typical transients, however in extreme circumstances it may be necessary to temporarily disconnect the auxiliary supply for a period of greater than 5 seconds to restore correct operation.
- Screened communication and small signal leads are recommended and may be required. These and other

Digital Metering Systems  
Communications Adaptor and Optical  
to Digital Adaptor

connecting leads may require the fitting of RF suppression components, such as ferrite absorbers, line filters etc., if RF fields cause problems.

- It is good practice to install sensitive electronic instruments that are performing critical functions in EMC enclosures that protect against electrical interference causing a disturbance in function.

**Easier Measurement**

When using this adaptor and a computer, the making of measurements, their recording and presentation, is now even simpler.

Transducers used in applications like AC power measurement and industrial processes traditionally do not provide RS232 communication facilities, relying instead on 4/20mA analogue signals as inputs for computerised measurements.

This adaptor avoids the cost and limitations of 4/20mA wiring and the required computer cards and PLC input modules.

Additionally it offers new possibilities as it accepts up to eight input signals and uses single low cost optical output cable, making it easier to use.

Optical cable is increasingly being used as an interference free transmission system, and will permit RS232 data to be sent over a 100 metre distance with lower overall cost, excellent isolation, ground loop avoidance and EMC protection.

Unlike hardwired RS232 cables, the optical cable can be sited with complete confidence near AC power cables, switchgear and other equipment that generates interference spikes. Therefore, exceptional EMI/RFI/EMC interference protection is offered which avoids data corruption.

The on-board 5V source can be used as a wetting voltage to determine the state of relay contacts elsewhere in the system.

**Functional Information**

This communications adaptor has 8 inputs, all sharing a common ground. The auxiliary supply, analogue and digital circuits and microcontroller convert the inputs to an output data stream. All channels are first measured in sequence and then, all data is transmitted in a single message, after which the delay if any, is implemented. As the receiving computer requires time to service system work elsewhere, transmission free periods may be required and therefore the user selectable delay period is provided. The Baud rate is also user selectable for this reason and to permit matching to related system requirements. The output is via optical RS232, standard.

The adaptor consists of three separate parts; transmitting units, optical cable link and receiver D socket.

**Screw torque**

Main terminal screws should be tightened to 1.35Nm or 1.0 ft/lbf only. Detachable terminal connector screws should be tightened to 0.9Nm or 0.7 ft/lbf only. Where fitted, terminal covers are held in place by miniature self tapping screws into plastic. These screws should be tightened by hand only, sufficiently to secure the terminal cover and prevent it vibrating.



# INSTALLATION INSTRUCTIONS

## Digital Metering Systems

### Communications Adaptor and Optical to Digital Adaptor

Page 2 of 2

Ref: IWTC A – Rev 4 – March 02

#### Fusing and connections

This unit must be fitted with external fuses in voltage and auxiliary supply lines. Voltage input lines must be fused with a quick blow fuse 1A maximum. Auxiliary supply lines must be fused with a slow blow fuse rated 1A maximum. Choose fuses of a type and with a breaking capacity appropriate to the supply and in accordance with local regulations.

#### Software

The data stream can be viewed on screen using any commercially available modem program. Typical names are Procomm, Xtalk, Terminal, etc. A simple Crompton program is available showing the data on IBM PC.

#### Connection Diagrams

##### 25D-ODA

Pin 2 = Data  
4 & 5 = Power for ODA  
6 & 20 = Power for ODA  
7 = ground

##### 9D-ODA

Pin 2 = Data  
4 & 6 = Power for ODA  
7 & 8 = Power for ODA  
5 = ground

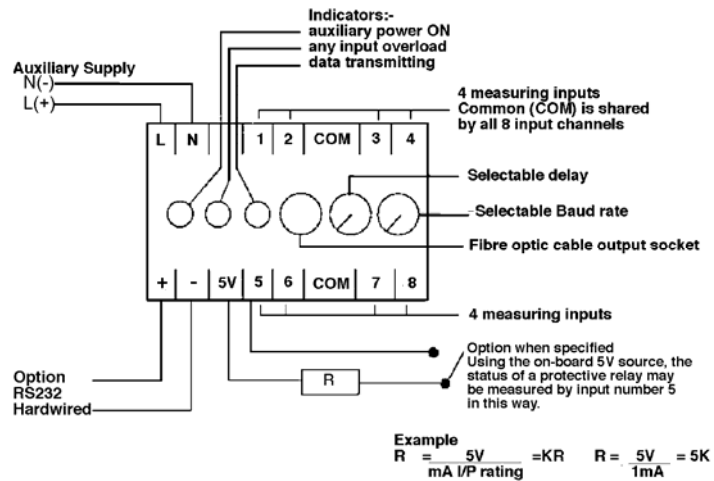

#### Dimensions

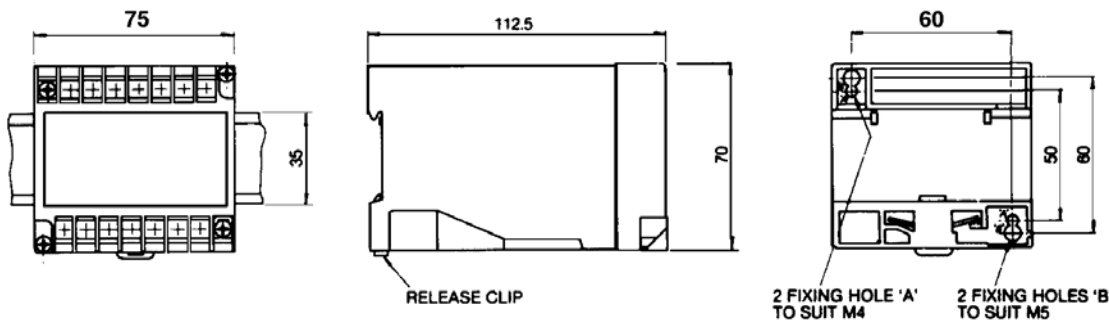

Never open circuit the secondary winding of an energised current transformer. This product is manufactured by Crompton Instruments, Freebournes Road, Witham, Essex, England. CM8 3AH. Telephone: +44 (0) 1376 509509, Fax: +44 (0) 1376 509511.

**LOW VOLTAGE DIRECTIVE:** This product complies with BSEN61010-1

#### Warning

- During normal operation, voltages hazardous to life may be present at some of the terminals of this unit. Installation and servicing should be performed only by qualified, properly trained personnel' abiding by local regulations. Ensure all supplies are de-energised before attempting connection or other procedures.
- It is recommended adjustments be made with the supplies de-energised, but if this is not possible, then extreme caution should be exercised.
- Terminals should not be user accessible after installation and external installation provisions must be sufficient to prevent hazards under fault conditions.

The Information contained in these installation instructions is for use only by installers trained to make electrical power installations and is intended to describe the correct method of installation for this product. However, Tyco Electronics has no control over the field conditions, which influence product installation. It is the user's responsibility to determine the suitability of the installation method in the user's field conditions. Tyco Electronics' only obligations are those in Tyco Electronics' standard Conditions of Sale for this product and in no case will Tyco Electronics be liable for any other incidental, indirect or consequential damages arising from the use or misuse of the products. Crompton is a trade mark.



Tyco Electronics UK Limited

Crompton Instruments

Freebournes Road, Witham, Essex, CM8 3AH, UK

Phone: +44 1376 509 509 Fax: +44 1376 509 511

<http://energy.tycoelectronics.com>