

**Products Covered**

256-PLL	256-PLD	256-PAS
256-PAQ	256-PAT	256-PAR

**Introduction**

Models 256-PLL, 256PLD

Paralleling Protector modules provide manual/automatic switching of generator to busbar.

The volt free relay contacts change state when voltage, phase relationship and frequency are within the selected synchronising limits.

Models 256-PAS, 256-PAT, 256-PAQ, 256-PAR

Reverse Power Protectors monitor the current and power factor of a.c generators connected in parallel with another generator or with the a.c mains and give an alarm or control signal should power flow into the generator (i.e. reverse power) exceed a user-adjusted level.

Model 256-PAQ and 256-PAR have a push to test button.

**Warning**

- During normal operation, voltages hazardous to life may be present at some of the terminals of this unit. Installation and servicing should be performed only by qualified, properly trained personnel' abiding by local regulations. Ensure all supplies are de-energised before attempting connection or other procedures.
- It is recommended adjustments be made with the supplies de-energised, but if this is not possible, then extreme caution should be exercised.
- Terminals should not be user accessible after installation and external installation provisions must be sufficient to prevent hazards under fault conditions.
- This unit is not intended to function as part of a system providing the sole means of fault protection - good engineering practice dictates that any critical function be protected by at least two independent and diverse means.
- Never open circuit the secondary winding of an energised current transformer.

**Installation**

The Protector should be installed in a dry position, not in direct sunlight and where the ambient temperature is reasonably stable and will not be outside the range 0-60 degrees Celsius. Mounting will normally be on a vertical surface but other positions will not affect the operation and vibration should be kept to a minimum. The Protectors are designed for mounting on a 35mm rail to DIN 46277. Alternatively they may be screw fixed.

To mount a protector on a DIN rail, the top edge of the cut-out on the back is hooked over one edge of the rail and the bottom edge carrying the release clip clicked into place. Check that the unit is firmly fixed. Removal or repositioning may be achieved by levering down the release clip and lifting the unit up and off the rail.

**Electromagnetic Compatibility**

This unit has been designed to provide protection against EM (electromagnetic) interference in line with requirements of EU and other regulations. Precautions necessary to provide proper operation of this and adjacent equipment will be installation dependent and so the following can only be general guidance:-

- Avoid routing wiring to this unit alongside cables and products that are, or could be, a source of interference.
- The auxiliary supply to the unit should not be subject to excessive interference. In some cases, a supply line filter may be required.

Protector Trip Relays  
DIN Rail & Wall Mounted 250 Series  
Paralleling & Reverse Power

- To protect the product against incorrect operation or permanent damage, surge transients must be controlled. It is good EMC practice to suppress differential surges to 2kV or less at the source. The unit has been designed to automatically recover from typical transients, however in extreme circumstances it may be necessary to temporarily disconnect the auxiliary supply for a period of greater than 5 seconds to restore correct operation.
- Screened communication and small signal leads are recommended and may be required. These and other connecting leads may require the fitting of RF suppression components, such as ferrite absorbers, line filters etc., if RF fields cause problems.
- It is good practice to install sensitive electronic instruments that are performing critical functions in EMC enclosures that protect against electrical interference causing a disturbance in function.

**Fusing and connections**

1. This unit must be fitted with external fuses in voltage and auxiliary supply lines.
2. Voltage input lines must be fused with a quick blow fuse 1A maximum.
3. Auxiliary supply lines must be fused with a slow blow fuse rated 1A maximum.
4. Choose fuses of a type and with a breaking capacity appropriate to the supply and in accordance with local regulations.
5. Where fitted, CT secondaries must be grounded in accordance with local regulations.

**Screw torque**

Main terminal screws should be tightened to 1.35Nm or 1.0 ft/lbf only. Detachable terminal connector screws should be tightened to 0.9Nm or 0.7 ft/lbf only. Where fitted, terminal covers are held in place by miniature self tapping screws into plastic. These screws should be tightened by hand only, sufficiently to secure the terminal cover and prevent it vibrating.

**Setting Up**

**Model 256-PLL**

The module is connected to monitor voltage values from both busbar and incoming generator systems. The generator supply powers the electronics and the relay. The input signals are compared for voltage level and phase relationship and when the resultant is below the selected limit a command signal energises the relay. A time delay ensures frequencies are virtually equal at synchronising.

**Model 256-PLD**

This operates in the same way as the type 256-PLL, with the addition of the "Dead Bus" facility. This extra feature enables the relay to energise with a generator supply only. Thus the 256-PLD will allow the generator to power the busbar during mains failure.

**Models 256-PLL and 256-PLD**

The front mounted, calibrated control should be set to suit operational requirements. A red LED on the front indicates, when lit, that the output relay is in the energised state.

**Models 256-PAS, 256-PAT, 256-PAQ & 256-PAR**

All reverse power units have front mounted, calibrated controls and these should be set to suit operational requirements. A red LED on the front indicates, when lit, that the output relay is in the energised state. The output relay is normally arranged to energise on trip. Note, this means that it is necessary to know whether the output relay is arranged to energise or de-energise on trip before the tripped or untripped state of a Protector can be determined from the condition of the LED. The working range is power factors between 0.5 inductive / Unity / 0.25 Capacitive



**Protector Trip Relays  
DIN Rail & Wall Mounted 250 Series  
Paralleling & Reverse Power**

**All Models**

The calibration marks around the controls are provided as a guide if the installer does not have access to accurate equipment. The maximum error of the calibration marks is typically 10% of the span of the control concerned.

**Maintenance**

The unit should be inspected to normal standards for this class of equipment. For example remove accumulations of dust and check all connections for tightness and corrosion. In the unlikely event of a repair being necessary it is recommended that the unit be returned to the factory or to the nearest Crompton Instruments Service Centre.

**Connection diagrams**

Connection diagrams should be carefully followed to ensure correct polarity and phase rotation. External current and voltage transformers may be used to extend the range.

**Models 256-PAS, 256-PAT, 256-PAQ & 245-PAR**

Note: Only one CT connection is required

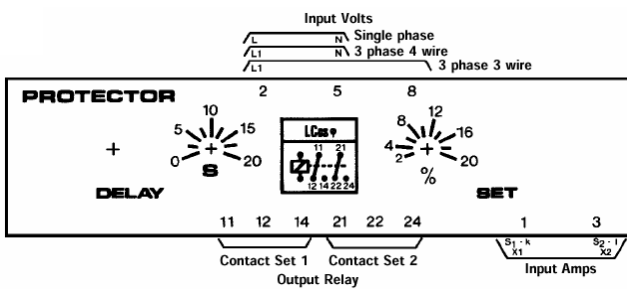

**Dimensions**

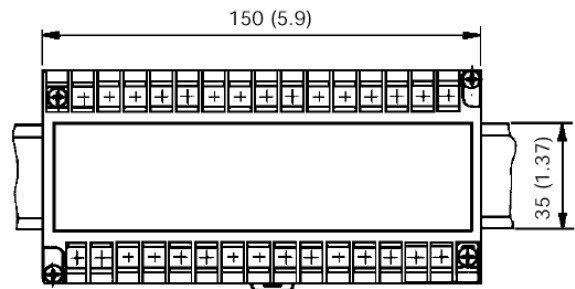

**256-PAS & 256-PAQ  
Single Phase or 3 Phase 4 Wire**

**256-PAT & 256-PAR  
3 Phase 3 Wire**

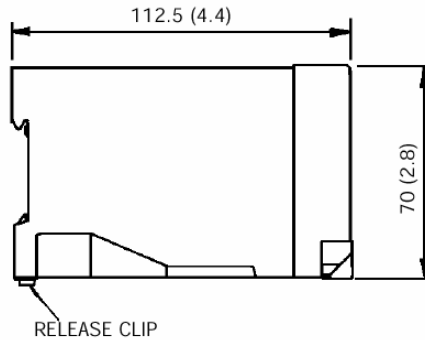
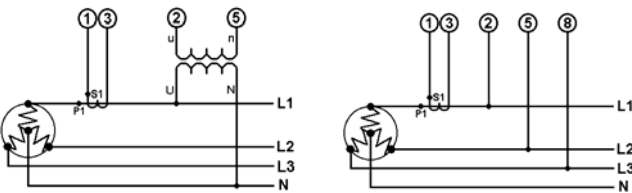

**Models 256-PLL & 256-PLD**

Note: When systems are in synchronism and within the selected limits contacts 5 & 6 are closed and contacts 7 & 8 are open.

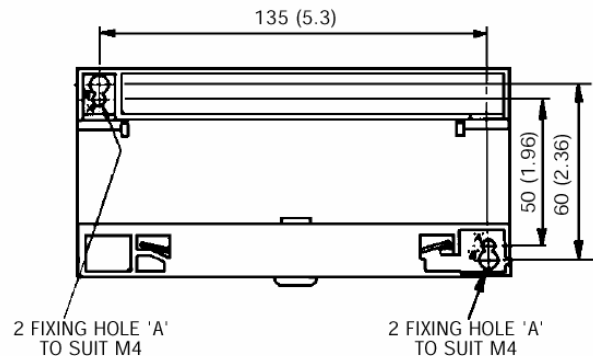
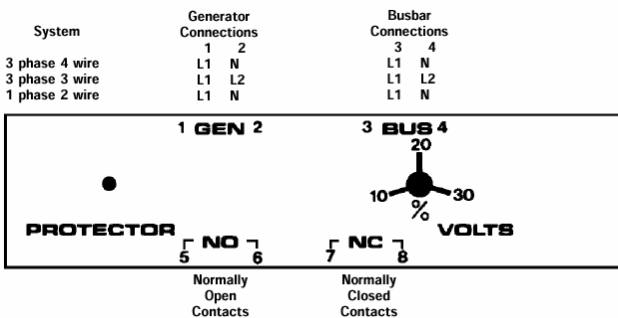

The Information contained in these installation instructions is for use only by installers trained to make electrical power installations and is intended to describe the correct method of installation for this product. However, Tyco Electronics has no control over the field conditions, which influence product installation. It is the user's responsibility to determine the suitability of the installation method in the user's field conditions. Tyco Electronics' only obligations are those in Tyco Electronics' standard Conditions of Sale for this product and in no case will Tyco Electronics be liable for any other incidental, indirect or consequential damages arising from the use or misuse of the products. Crompton is a trade mark.

