

Products Covered

256-TAB	256-TAL	256-TAR	256-TAS	256-TVL
256-TRV	256-TVS	256-TW*	256-TX*	
256-TY*	256-TT*	256-X**	(* = varies)	

Paladin Transducers, Class 0.5 256-T Series and Class 0.2 256-X Series Current, Voltage, Frequency, Power & DC input



Caution: Risk of Danger

These instructions contain important safety information: Read before starting installation or servicing of the equipment



Caution: Risk of Electric Shock

Introduction

Paladin Transducers give a dc output proportional to the input and up to three outputs from one transducer in the case of 256-X, 256-TA and 256-TV. Zero and span adjustments are accessible without opening the transducer.

Ratings

Side labels show product function, and electrical ratings for measurement inputs and auxiliary supplies where applicable. Product side labels show full connection information. Terminal numbers are identified on the coloured foil label adjacent to the terminals and correspond with those shown on the connection diagram. DC outputs of these transducers include an internal power supply and may be connected directly across a passive load as stated on the rating label.

DC output circuits are separated from metering inputs and auxiliary circuits by at least basic insulation. Such DC output circuit terminals are only suitable for connection to equipment which has no user accessible live parts. The insulation for such auxiliary circuits must be rated for the highest voltage connected to the instrument and suitable for single fault condition. The connection at the remote end of such auxiliary circuits should not be accessible in normal use. Depending on application, equipment connected to auxiliary circuits may vary widely. The choice of connected equipment or combination of equipment should not diminish the level of user protection specified. These units are designed for operation between 0 and 60 deg C at less than 80% relative humidity for temperatures up to 31 deg C, decreasing linearly to 50% relative humidity at 40 deg C, for indoor use at an altitude of less than 2000m.

Installation

These Transducers should be installed in compliance with electrical codes for the territory of final use. For example for USA, in line with National Electrical Code and for Canada in line with Canadian Electrical Code. They should be installed in a dry position, not in direct sunlight and where the ambient temperature is reasonably stable and will not be outside the range noted above. Terminals should not be user accessible after installation. Mounting will normally be on a vertical surface but other positions will not affect operation. Vibration should be kept to a minimum. Transducers are designed for mounting on a 35mm rail to DIN 46277. Alternatively they may be screw fixed. These units may be mounted adjacent to other DIN rail products on the same rail, however at least 35mm (1.5 inches) of free air space should be allowed above and below the transducer. To mount a Transducer on a DIN rail, position the transducer with the black release clip on the lowest face. Clip the transducer over the top edge of the rail and click the bottom edge carrying the release clip into place. Check that the unit is firmly fixed. Removal or repositioning may be achieved by levering down the release clip and lifting the unit up and off the rail. These units do not require a protective earth, but where fitted, current transformer (CT) secondaries must be connected to protective earth in accordance with local regulations.

Connections and Fusing

Connection diagrams should be carefully followed to ensure correct polarity and phase rotation where applicable. External voltage transformers (PTs) and CTs may be used to extend the range, provided that transducer ratings are not exceeded at the point of connection to transducer.

These products do not have internal fuses therefore external fuses **must** be used for safety protection under fault conditions.

Voltage input lines must be fused with a quick blow fuse 1A maximum. Auxiliary supply lines must be fused with a slow blow fuse rated 1A maximum. Do not fuse CT connections. DC current inputs should be fused according to the rated current of the transducer. Choose fuses of a type and with a breaking capacity appropriate to the supply and in accordance with regulations.

Connection wires should be sized to comply with applicable regulations and codes of practice, and be rated for minimum 75 deg C. Terminals are suitable for use with one or two copper wire conductors per terminal, AWG12 (3 mm²) or less. Wiring is to comply with class 1 requirements in North America.

Tighten terminal screws to 1.35Nm (1 ft/Lb) only. Ensure all connection wires are rated and approved to the highest voltage connected to the transducer.

Note that minimum wire current ratings for CT circuits ensure that the wire is capable of carrying the current safely, however it may be desirable to use heavier gauge wiring, particularly for long cable runs to ensure that the CT class accuracy VA rating is not exceeded and it's accuracy impaired.

The equipment into which these transducers are installed must have a readily accessible, clearly marked, adjacent switch or circuit breaker which will isolate the supply voltage and permit safe access for subsequent maintenance.

These products offer electrical isolation between measurement inputs and outputs in accordance with IEC1010-1 (BSEN 61010-1) Permanently connected use, Normal Condition Measurement category III, pollution degree 2 (e.g. non ventilated panels or ventilated panels with filters, without condensation occurring), Basic Insulation, for rated voltage.

Multiple output 256-X transducer connections

When installing a 256-X transducer with 2 or 3 outputs, do not common the negative terminals. All outputs must be galvanically isolated. Where appropriate, users may fit a 250-ISA signal isolator to the second and third outputs, and the negative terminals of the first 256-X output and the 250-ISA outputs commoned.

Note: Multiple outputs on 256-TA and 256-TV models may be commoned at the negative or positive terminal as required.

Maintenance

No routine maintenance is required, beyond removing any accumulations of dust or other foreign matter and ensuring that connection screws remain tight.

Warning

- During normal operation, voltages hazardous to life may be present at some of the terminals of this unit. Installation and maintenance should be performed only by qualified, properly trained personnel' abiding by local regulations. Ensure all supplies are isolated before attempting connection or maintenance.
- It is recommended adjustments be made with the supplies isolated, but if this is not possible, then extreme caution should be exercised.
- This unit is not intended to function as part of a system providing the sole means of fault protection - good engineering practice dictates that any critical function be protected by at least two independent and diverse means.
- Never open circuit the secondary winding of an energised current transformer.
- If this equipment is used in a manner not specified by the manufacturer, protection may be impaired.

Commissioning

The units are calibrated at the factory for full accuracy. No further adjustments are required. Zero and span adjustment where provided are under the bungs on the front panel. Resetting these will degrade the accuracy of this transducer, but may be used to compensate for system errors etc. Typically adjustment of 10% of span and 2% of zero is available, but this varies by model..

Electromagnetic Compatibility

This unit has been designed to provide protection against EM (electro-magnetic) interference in line with requirements of EU, FCC and other regulations. Precautions necessary to provide proper operation of this and adjacent equipment will be installation dependent and so the following can only be general guidance:-

- Avoid routing wiring to this unit alongside cables and products that are, or could be, a source of interference.
- The auxiliary supply to the unit should not be subject to excessive interference. In some cases, a supply line filter may be required.
- To protect the product against incorrect operation or permanent damage, surges and transients must be controlled. It is good EMC practice to suppress transients and surges at the source.
- Screened small signal leads are recommended and may be required. Connecting leads may require the fitting of RF suppression components, such as ferrite absorbers or line filters
- It is good practice to install sensitive electronic instruments that are performing critical functions in EMC enclosures that protect against electrical interference causing a disturbance in function.

For assistance on protection requirements please contact your local sales office.

Dimensions

(Note 256-X models do not include corner keyholes for surface mounting)

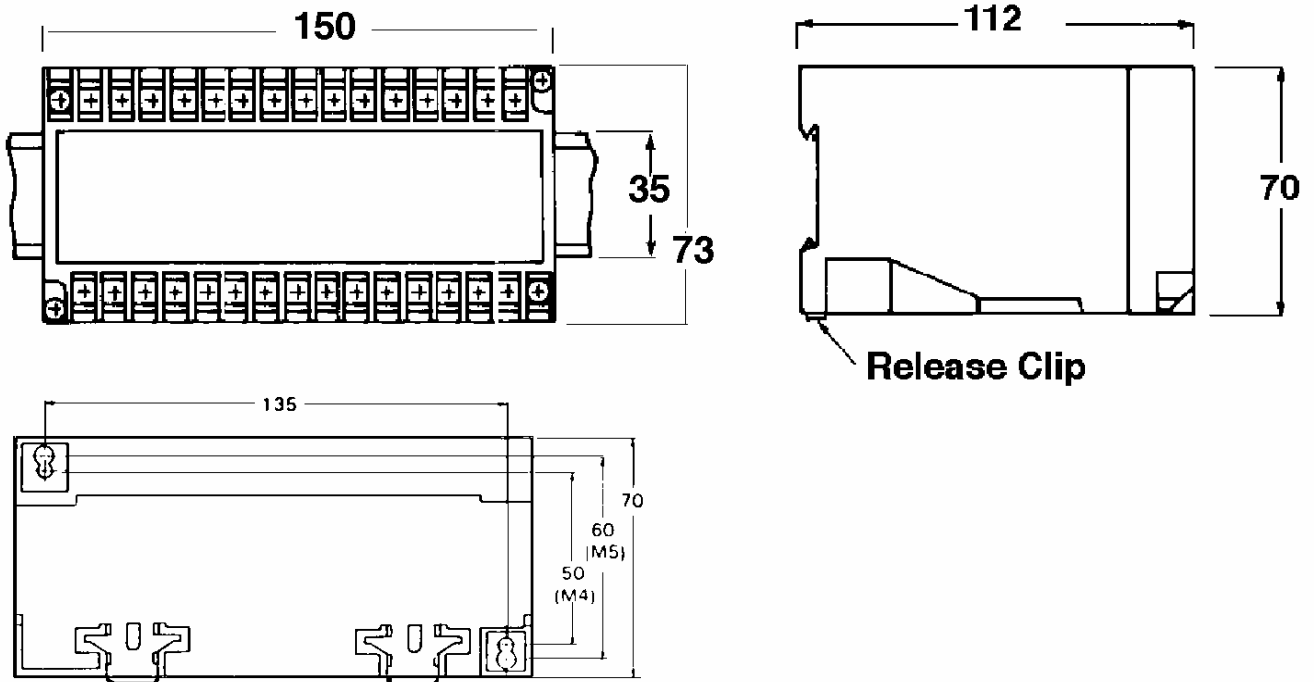

Rear View Showing Panel Mounting Holes

Arrangement for commoning 256-X negative output terminals.

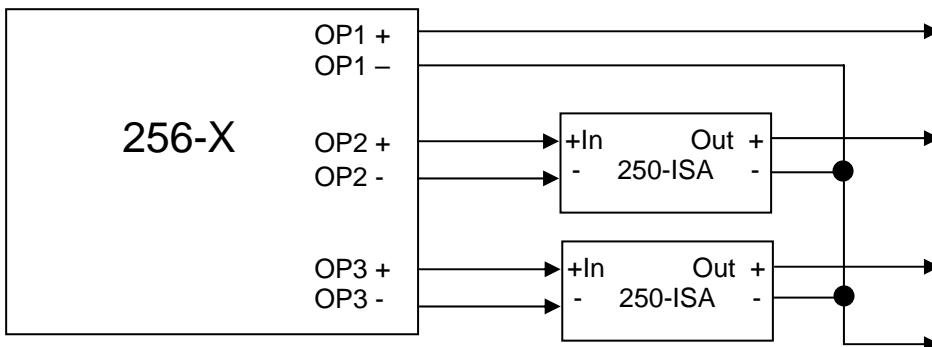

All of the above information, including drawings, illustrations and graphic designs, reflects our present understanding and is to the best of our knowledge and belief correct and reliable. Users, however, should independently evaluate the suitability of each product for the desired application. Under no circumstances does this constitute an assurance of any particular quality or performance. Such an assurance is only provided in the context of our product specifications or explicit contractual arrangements. Our liability for these products is set forth in our standard terms and conditions of sale.

Tyco Electronics UK Limited
 Energy Division
 Freebournes Road, Witham, Essex, CM8 3AH, UK

Phone: +44 (0)870 870 7500
 Fax: +44 (0)870 240 5287
 www.crompton-instruments.com

